

# TL Series

## Modular Heat Sinkable Thick Film Power



The TL Series add heat sinkable options to the thick film resistor family. The resistor element is packaged with plastic insulators, and quick-connect terminals in a symmetrical aluminum profile for easy heat sink mounting. Special tapped configurations are offered to reduce on board component count.

Efficient thermal packaging provides improved heat conduction to the heat sink. Self-insulating package design increases voltage withstanding characteristics when compared to traditional aluminum housings. The in line mounting profile makes the TL Series easily adaptable to most heat sink systems. Thermal compound is always recommended when heat sinking.

### FEATURES

- Very low inductance
- Low profile design
- In-Line Mounting Profile
- 1/4" Quick connect terminals
- Consult factory for common, isolated, or special multiple tap options.

### APPLICATIONS

- Semiconductor Balancing
- Frequency Converters
- Snubber
- In-Rush Current Limiter
- Bleeder Resistor
- Power Switching
- Voltage Dividers

### SERIES SPECIFICATIONS

Series	Ultra*	Std**	Nominal Power	Surge Load (10 sec.)	Max. Voltage between terminals	Ohm Range	Thermal Resistance	
	Wattage	Wattage					Ultra (10% tol.)	Std. (3%-5% tol.)
TL54	35	27	18	72	1000	0.3Ω - 1MΩ	1.26	1.67
TL71	96	71	48	192	2000	1.0Ω - 2MΩ	0.53	0.70
TL88	155	114	78	312	2500	1.5Ω - 3MΩ	0.34	0.45
TL104	215	158	108	432	2500	2.0Ω - 4MΩ	0.25	0.33
†TL122	275	202	137	548	2500	2.0Ω - 4MΩ		

\* For properly heat sinked, untrimmed resistors - see chart

\*\* For properly heat sinked, trimmed resistors - see chart

† Power Ratings are theoretical. Consult Factory for details.

### CHARACTERISTICS

Operating voltage	1200 VAC
Dielectric Withstanding Voltage	2500 VAC
Resistive Element	Thick Film on Alumina
Housing	Aluminum
Insulators	Glass reinforced high temperature Valox®
Terminals	Tinned brass
Power Range	27 - 275 watts
Resistance Range	0.3Ω - 4MΩ
Tolerance	Ultra Power (U Style): ±10% std. Standard Power: ±10% std.; 5% and 1% available
Temperature Coefficient	±250 PPM
Test Voltage for 1 Minute	6000 VDC/2500 VAC
Working Voltage	1200 VAC
External Creeping Distance	12mm
Temperature Limits	-40°C to +125°C
Insulation	>1002 MΩ/500V
Air Distance, Terminal to Ground	7mm
Inductance	50-100 nH

### THIS PRODUCT IS DESIGNED FOR USE WITH PROPER HEATSINKING.

Maximum base plate temperature of the resistor must be monitored and kept within specified limits to establish the power rating. Best technique is to attach a thermocouple to the side of the base plate of the resistor. Temperature of plastic housing or heat sink cannot be used to establish rating of the resistor.

(continued)

# TL Series

## Modular Heat Sinkable Thick Film Power

### POWER RATINGS

Maximum and nominal power ratings for Ultra Power and Standard Power resistors

TL54

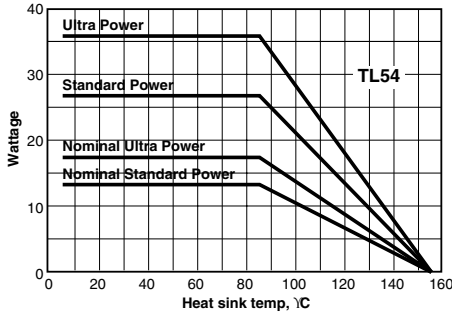

TL104

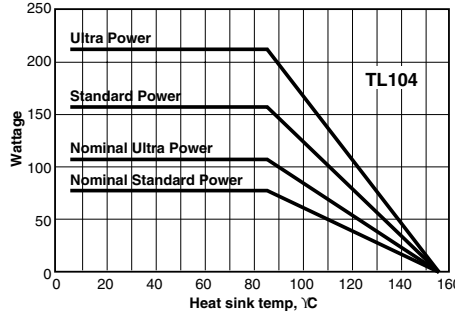

TL71

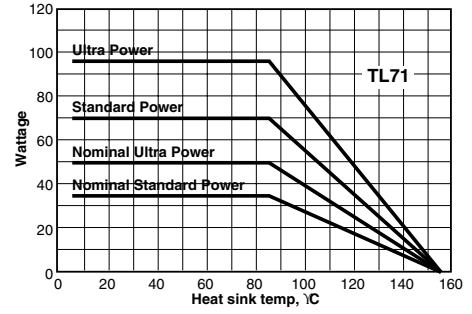

TL122

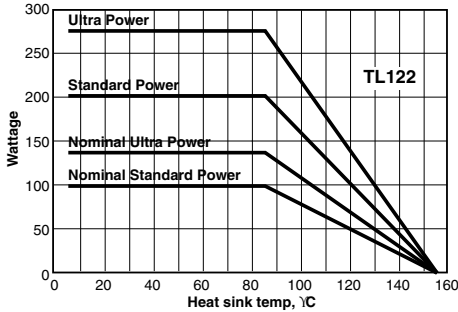

TL88

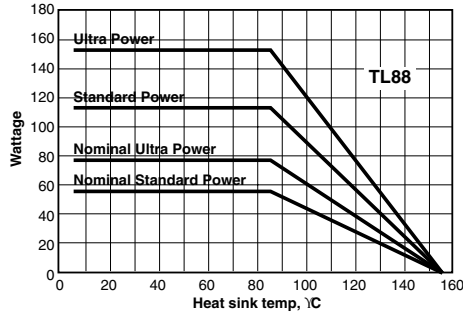

### ORDERING INFORMATION

E = RoHS compliant

**TL104KUR500CE**

Size	Tolerance	Power	Ohms	Center tap (optional)
TL54 = 54 mm	F = 1%	U = ultra (optional)	R500 = 0.50	
TL71 = 71 mm	J = 5%		10R0 = 10.0	
TL88 = 88 mm	K = 10%		1K00 = 1,000	
TL104 = 104 mm			1M00 = 1,000,000	
TL122 = 122 mm				

### Standard part numbers

Ohmic value	Part No.					Ohmic value	Part No.							
	Prefix	Suffix	TL54K	TL71K	TL88K		TL104K	TL122K	Prefix	Suffix	TL54K	TL71K	TL88K	TL104K
0.5	—	R50	✓			240.0	—	240	✓	✓	✓	✓	✓	✓
1.0	—	1R0	✓	✓	✓	470.0	—	470	✓	✓	✓	✓	✓	✓
1.5	—	1R5	✓	✓	✓	510.0	—	510	✓	✓	✓	✓	✓	✓
2.0	—	2R0	✓	✓	✓	750.0	—	750	✓	✓	✓	✓	✓	✓
3.0	—	3R0	✓	✓	✓	1,000.0	—	1K0	✓	✓	✓	✓	✓	✓
4.0	—	4R0	✓	✓	✓	1,100.0	—	1K1	✓	✓	✓	✓	✓	✓
5.1	—	5R1	✓	✓	✓	2,200.0	—	2K2	✓	✓	✓	✓	✓	✓
10.0	—	10R	✓	✓	✓	4,700.0	—	4K7	✱	✱	✱	✱	✱	✱
15.0	—	15R	✓	✓	✓	5,100.0	—	5K1	✱	✱	✱	✱	✱	✱
22.0	—	22R	✓	✓	✓	10,000.0	—	10K	✱	✱	✱	✱	✱	✱
47.0	—	47R	✓	✓	✓	22,000.0	—	22K	✱	✱	✱	✱	✱	✱
75.0	—	75R	✓	✓	✓	51,000.0	—	51K	✱	✱	✱	✱	✱	✱
100.0	—	100	✓	✓	✓									
150.0	—	150	✓	✓	✓									
220.0	—	220	✓	✓	✓									

✓ = Standard values  
 ✱ = Non-standard values subject to minimum handling charge per item

### DIMENSIONS

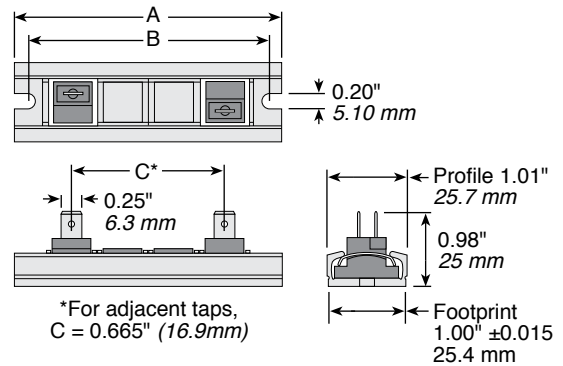

	TL54	TL71	TL88	TL104	TL122
A	mm 54	71	88	104	122
B	mm 46	63	80	96	114
C	mm 16.9	33.8	50.7	67.6	84.5
Weight	g 26	33	44	55	65

Consult factory for multiple tap options in common, isolated, and special configurations.